

## Features

- **Collapsible Element Design**  
with removeable “gamma match” element
- **Transmit & Receive Capabilities**  
emissions/immunity applications
- **Individual Calibration Included**  
per ANSI C63.5 or SAE ARP958 with NIST traceability

## Description

The ABF-900A is a broadband, linearly polarized Biconical Dipole Antenna with collapsible elements, operating over the frequency range of 25 MHz to 300 MHz. Each full-size biconical element (54 cm cage diameter) collapses to a maximum diameter of 5 cm for easy transport/storage.

## Construction

The antenna elements are constructed of a corrosion resistant, polished aluminum. The ABF-900A is the only collapsible-element Biconical Antenna which incorporates a “gamma match” rod. It is necessary in order to avoid a significant “dip” in the antenna’s performance, which would otherwise be present between approximately 275 and 290 MHz.

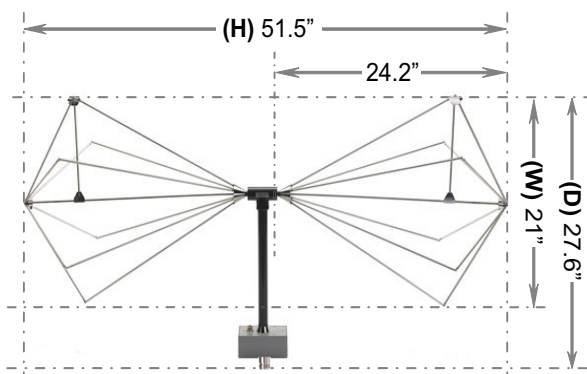

## Calibration

Each antenna is individually calibrated per ANSI C63.5 or SAE ARP958 with NIST traceability. The calibration data and certificate is provided. Recognized ISO 17025 accredited calibration is also available upon request.

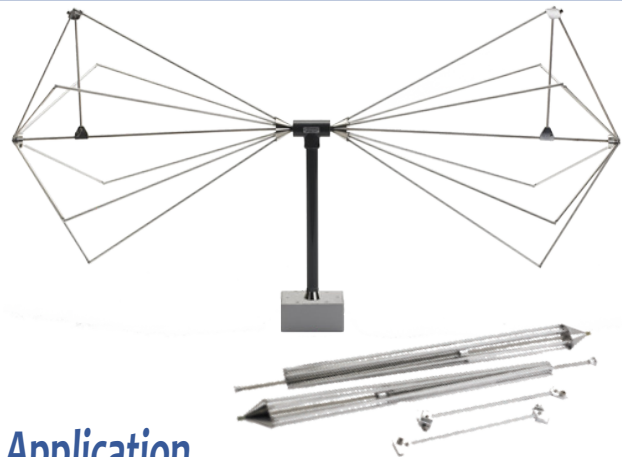

## Application

The ABF-900A Biconical Antenna is intended for use as an EMI test antenna for qualification-level regulatory compliance measurements (FCC, CE, Mil-Std, RTCA DO-160, FDA, SAE Automotive, etc.).

The ABF-900A can also be used in conjunction with an RF power amplifier (up to 50 watts) to generate RF fields associated with radiated immunity tests.

In addition, a pair of ABF-900A Biconical Antennas can also be used for Normalized Site Attenuation (NSA) calibrations of Open Area Test Sites (OATS) or Semi-Anechoic Chambers (SAC) using the Geometry Specific Correction Factors (GSCF) given in Tables G.1 through G.3 of ANSI C63.5, as its physical dimensions conform to the minimum and maximum values given in Figure G.1 of ANSI C63.5 (Dimensions of biconical dipole antennas evaluated for numerical correction). If biconical antennas have dimensions which do not conform to these min/max values, the given GSCF values can not be used, and would need to be determined by performing GSCF calibration on a Standard Antenna Calibration Site (SACS) as described in Annex H of ANSI C63.5.

Notwithstanding the above applications, the ABF-900A can also be used for test site comparisons, shielding effectiveness tests of large enclosures, field monitoring, site surveys and other general purposes.

## Mounting

The recommended support structures for the ABF-900A are Com-Power’s **AM-400 Antenna Mast** and **AT-812 Antenna Tripod**. One of the standard AT-812 accessories is the **ATHP-812 Antenna Pipe Holder**, which clamps securely around the one-inch diameter feed tube of the ABF-900A. The ATHP-812 is then secured to a tripod or mast via its 1/4" x 20 thread mounting hole.

### Specifications

Product Name	<b>Biconical Antenna</b> (with collapsible elements)
Frequency Range	<b>25 MHz to 300 MHz</b>
Polarization	<b>Linear</b>
Nominal Impedance	<b>50Ω</b>
Power Handling	<b>50 Watts</b> (continuous)
Connector	<b>N-type</b> (female)
Antenna Factor	<b>6 to 21</b> (average: <b>12.6</b> ) [dB(m <sup>-1</sup> )]
Isotropic Gain	<b>-15 to 3</b> (average: <b>-2.9</b> ) dBi
VSWR/Return Loss	<b>1.2 to 34</b> (average: <b>8.1</b> ):1
Radiated Field Strength	see graphs below
Specifications	<b>FCC, CISPR, EN, ETSI, FAA, MIL-STD 461, Automotive, etc.</b>
Dimensions (H x W x D)	<b>51.5" x 21" x 27.6"</b> [130.8 x 53.3 x 70.1 cm]
Weight	<b>5.5 lbs.</b> [2.5 kg]

All specifications are subject to change without notice.  
All values are typical, unless specified.

### Accessories available from Com-Power:



PAM-103 Preamplifier



AT-812 Antenna Tripod

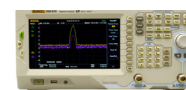

SPA-800 Spectrum Analyzer

### Also Available:

- AL-130 Active Loop Antenna
- AM-741 Active Monopole Antenna
- AL-100, ALP-100, ALC-100 Log Periodic Antennas

### Antenna Factors

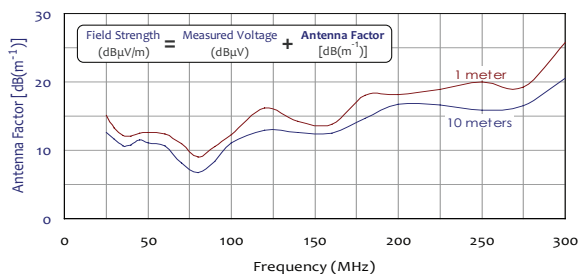

### Isotropic Gain

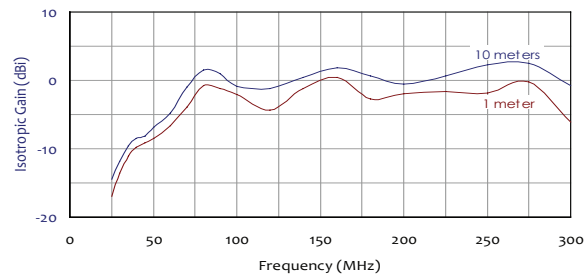

### Voltage Standing Wave Ratio (VSWR)

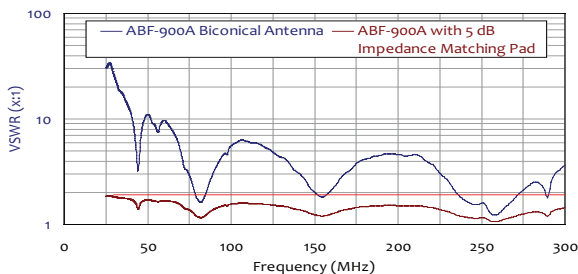

### Return Loss

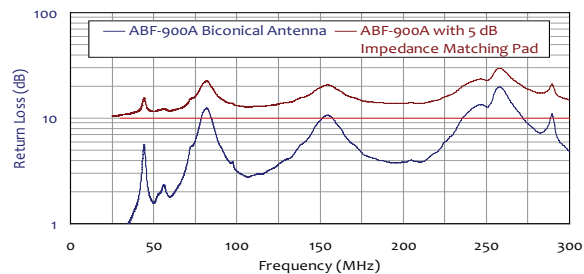

### Typical Field Strength with 50W Input Power

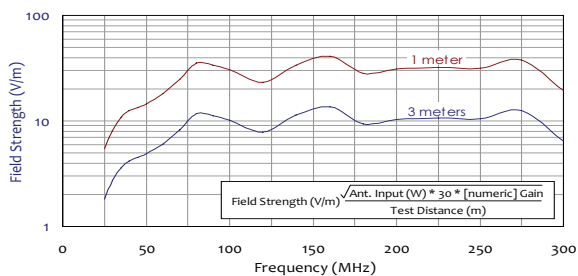

### Typical Forward Power Levels

