



**CDN 117 / 117-M
CDN 118-T4 / 118-EXT-1
SIGNAL & DATA LINE
COUPLING NETWORKS**

USER MANUAL 601-142M

**CDN 117 / 117-M
CDN 118-T4 / 118-EXT-1
SIGNAL & DATA LINE
COUPLING NETWORKS
USER MANUAL**

CONTENT

1	General	5
1.1	Safety	5
1.2	Safety measures	6
1.3	Installation	7
1.4	Test execution	8
2	Functional description	9
2.1	CDN 117	9
2.2	CDN 118	11
3	Test setups	12
3.1	Connections	12
3.2	Using CDN 117 for unshielded interconnection lines	13
3.3	Test setup for unshielded unsymmetrically operated lines with 1.2/50 μ s pulse	15
3.3.1	Using CDN 118-T4 for two or four lines testing	15
3.3.2	Using CDN 118-EXT-1 for eight lines testing	17
4	Technical specifications	19
4.1	Environmental conditions	21
4.2	Coupling assembly check list	21
5	Maintenance	23
5.1	Warranty	23
6	Addresses	24

1 GENERAL



The CDN 117 and CDN 118 coupling - decoupling networks provide a means for injecting standards-compliant surge pulses into signal and datalines, as well as telecom lines.

These networks are used in combination with surge generators. Tests can be performed on equipment, assemblies and installations while they are in operation. These tests and their required coupling methods are prescribed in various test standards (e.g. IEC/EN 61000-6-2, IEC/EN 61000-4-5).

Specifications and recommendations regarding the execution of the tests, and their severity, the permissible reaction by the equipment under test (EUT), etc. can be found in the relevant standards.

The CDN 117 with the suffix -M are shipped with a pair of cables that fit Teseq's NSG 3000 family generator or Modula. CDN 118-T4 and CDN 118-EXT-1 are shipped with cables for Teseq's NSG 3000 family generator or Modula. Cables for other generators are available as option.

1.1 Safety

The CDN 117 and CDN 118 coupling - decoupling networks are designed for operation with high voltage generators, which contain high energy levels.

Incorrect or careless operation can be lethal!

The following safety measures must be strictly and responsibly observed at all times.

Users must also comply with all safety advice that is provided with generators that are used with the CDN 117 and CDN 118.

6 Neither Teseq AG, Luterbach, Switzerland nor its associated sales organizations accept any responsibility for personal injury or for any material or consequential damage resulting from negligent operation of this equipment.

These instruments have been designed in conformity with the relevant safety regulations and provide all the necessary requirements for safe and reliable operation.

1.2 Safety measures

These operating instructions form an integral part of the equipment and must be carefully studied before putting the equipment into operation and must be available to the user at all times.



WARNING - The equipment must only be used by trained personnel.

Personnel fitted with a heart pacemaker must neither operate the equipment nor remain in the test vicinity when the generator is in operation.

These instruments are not designed for use in an explosive atmosphere.

The test equipment is to be set up in conformity with the relevant safety standards (e.g. VDE 104).

The coupling network housing must be properly grounded (earthed).

To ensure safe operation, only approved accessories, plugs, adapters, etc. are to be used.

The setup must offer insulation protection against voltage which is at least equal to the pulse voltage.

The pulse voltage must not be able to find its way to ungrounded metallic objects even if the EUT is faulty or fails.

Depending on the type of EUT and especially on its cabling, a considerable amount of interference can be radiated which could affect nearby systems and radio communication. These environmental interference effects to be controlled by the user through the use of suitable measures such as a Faraday cage, shielded cable runs, etc.

1.3 Installation

Since the CDN 117 and CDN 118 do not have their own power supplies, they have not been assigned a protection class. However, they are typically operated according to protection class 1 in view of their electrical connection to pulse generators and the metallic parts of their casing.

Local installation regulations must be respected to ensure the safe flow of leakage currents.



WARNING - Operation without a ground (protective earth) connection is forbidden!

Operate the equipment only in dry surroundings. Any condensation that occurs must be allowed to evaporate before putting the equipment into operation. Do not exceed the permissible ambient temperature, humidity or altitude.

Ensure that a reliable return path for the interference current is provided between the EUT and the generator. The reference ground plane and the ground connections to the instruments that are described in the relevant test standard will serve this purpose well.

These instruments should be opened only by a qualified specialist if specifically instructed to do so in the operating manual.

1.4 Test execution

The test area must be organized so that no unauthorized persons have access during execution of a test. If a safety contact (interlock) is used as a means of access control to the test area (e.g. Faraday cage), then an additional contact in series with any hazardous voltages or currents is necessary to provide protection for parts of the EUT that are in danger of being touched.

EUTs, together with their accessories and cables, are to be considered live during a test. The test generator must be stopped and the EUT supply interrupted before any work can be performed on the EUT. This can often be achieved by opening the interlock circuit, depending on the type of generator in use.

The EUT is to be tested only in a protective cage or under a hood which provides protection against electric shock and all manner of other dangers pertaining to the particular EUT.

The safety instructions for all instruments and associated equipment in the test setup are to be observed.

The configuration of the test setup is to be strictly in compliance with the methods described in the relevant standard to ensure that the test is executed in a compliant manner.



Note: Please use a NSG 3000 series generator with Ed.2 Surge module in combination with a CDN 117 / 118 for IEC 61000-4-5:Ed.2 testing and a NSG 3000 series generator with Ed.3 Surge module in combination with a CDN 117 / 118 for IEC 61000-4-5:Ed.3 testing.

2 FUNCTIONAL DESCRIPTION



The CDN 117 and CDN 118 coupling - decoupling networks, together with their accessories, provide a means to inject standardized surge pulses into signal, data and/or telecom lines.

These coupling networks can be used in situations where the inputs and outputs of mains-free connection lines must be tested for interference immunity.

The CDN 117 and 118 are designed to be used in conjunction with a surge pulse generator. They enable tests to be performed on equipment or systems while they are in operation, by eliminating the attenuation of the surge pulse by auxiliary equipment (AE). The AE must usually be protected by surge suppressors against the effects of excessively high residual currents. Relevant tests and coupling methods are described in the test standards IEC/EN 61000-6-1, IEC/EN 61000-6-2, IEC/EN 61000-4-5, etc.

2.1 CDN 117

The versatile CDN 117 can be used on either unscreened (or unshielded), **unsymmetrically driven signal lines** as well as **on unscreened signal and data lines**.

The network enables symmetric (line to line) and asymmetric (line to ground) coupling of 1.2/50 μ s hybrid pulses into pairs of conductors.

The test pulse is inductively decoupled from the input side of the CDN (AE terminals) so that the surge pulse is coupled as fully as possible to the EUT via the output terminals.

The integral 40 Ω series resistors raise the source impedance of the pulse generator to 40 Ω . (Since the 2 Ω output impedance of the generator is a complex quantity, the combined value of the generator plus 40 Ω lies closer to the required value of 40 Ω).

Several CDN 117s can be arranged in parallel for applications where more than two conductors must be decoupled. A special coupling cable is needed.

DC decoupling must be achieved with a coupler type INA 170 or INA 174A.

The coupling mode can be changed by relocating the connecting cable from the pulse generator.

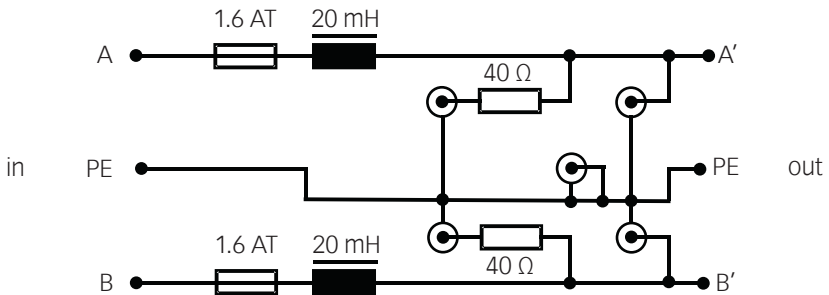

Functional schematic of the CDN 117

INA 170 The INA 170 contains a coupling spark gap without a capacitor. The spark gap has a trigger voltage of 90 V.

INA 174A The INA 174A contains a 0.5 μF capacitor that can be connected in series with the 40 Ω already incorporated in the coupling network. This type of coupling element is used for capacitive injection into unscreened signal and data lines.

2.2 CDN 118

This device is used on **unscreened** or **unshielded, symmetrically driven** telecommunication lines.

The network enables symmetric (line to line) and asymmetrical (line to ground) coupling of 1.2/50 and 10/700 μs pulses into pairs of conductors.

The test pulse is inductively decoupled from the input side of the CDN (AE terminals) so that surge pulse is coupled as fully as possible to the EUT.

A high value decoupling choke is required due to the large voltage-time characteristic of the 10/700 μs pulse.

The requisite series resistors are arranged in separate boxes so that all required modes can be achieved by proper connection of the INA 370 cable.

DC decoupling can be performed by using either the INA 170 coupling device.

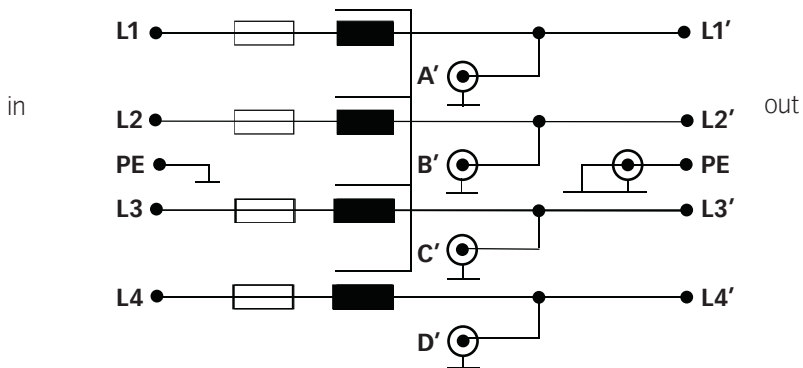

Functional schematic of the CDN 118

3 TEST SETUPS



Each test setup should be carefully planned. All the equipment should be securely positioned, and all cables should be securely connected.

The safety advice given in Sections 1 and 2 and in the generator manual must be observed. The EUT and the wiring should be handled only when the generator is not active.

Various test setups and test methods are possible. The following sections provide examples with more precise details.

3.1 Connections

There are two black safety laboratory sockets on the top left of the CDN 117. Both lines (L1 and L2) are marked as input and each is protected by a 1.6 A fuse. These input sockets share a common ground point which is internally and permanently connected to the housing of the coupling network. The signal or data lines from auxiliary equipment or loads, such as sensors, detectors, converters, temperature probes, switching elements, etc., are connected to these line inputs.

The output (out), to which the EUT must be connected, is positioned on the right hand side. The EUT could be, a computer, any type of signal amplifier, an evaluation device or a general type of central system controller.

The common ground socket is connected to the housing.

The pulse connections from the generator are plugged into two of the five high voltage sockets to obtain the required type of coupling.

Symmetrical coupling can only be achieved with generators with floating output. The connection of the coupling network to the high (+) and low (-) outputs of the generators are shown in the following diagrams.

3.2 Using CDN 117 for unshielded, unsymmetrical interconnection lines

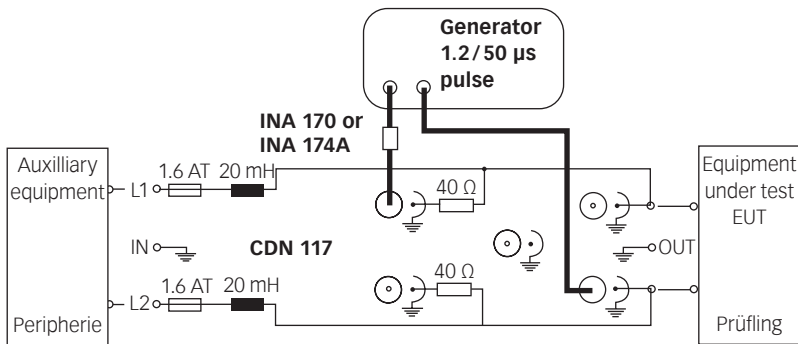

Line to line coupling, line L1 \rightarrow L2

If the coupling is changed from L2 \rightarrow L1, then the polarity from the generator can be swapped.

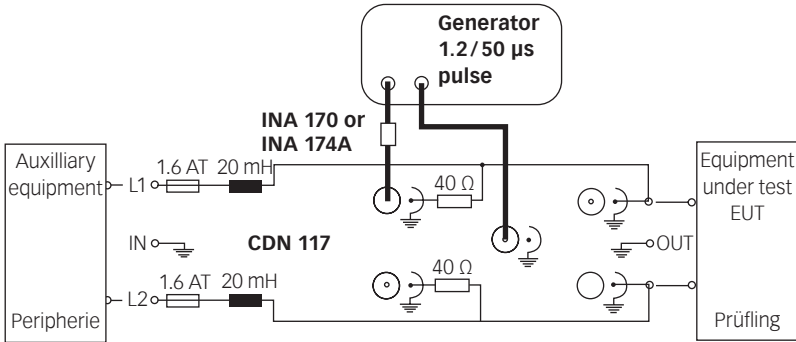

Line to ground coupling, line L1 → PE

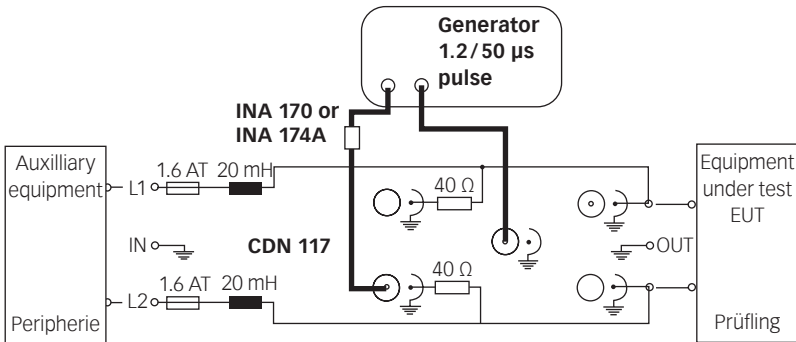

Line to ground coupling, line L2 → PE

3.3 Test setup for unshielded symmetrically operated lines with 1.2/50 or 10/700 μ s pulse

3.3.1 Using CDN 118-T4 for two or four lines testing

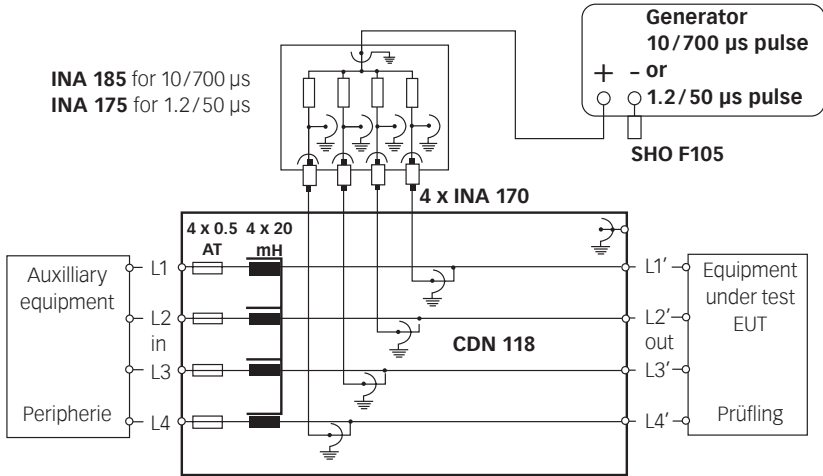

Line to ground coupling with 10/700 μ s or 1.2/50 μ s pulse on telecom lines

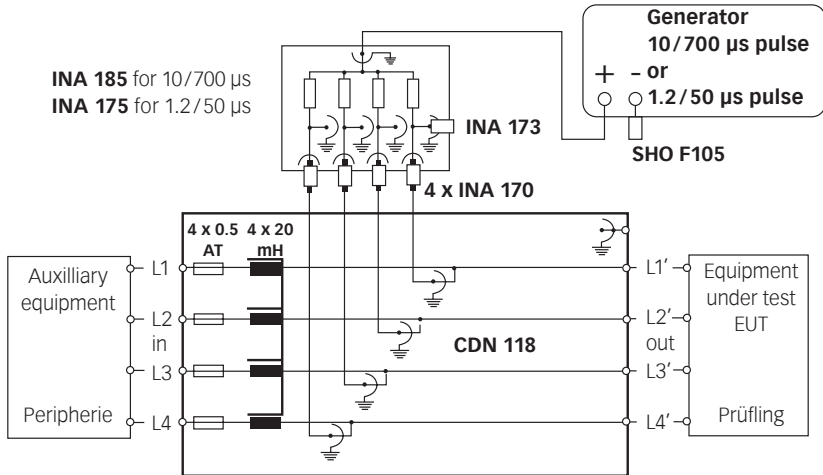

Line to line coupling with 10/700 µs or 1.2/50 µs pulse on telecom lines (1 line in turn grounded with INA 173). Please note this setup is not supported by IEC 61000-4-5 Edition 3.

EUT with two lines (one pair)

The INA 185 (4 x 25 Ω, only 2x 25 Ω in use) is to be used with a 10/700 µs pulse. Respectively, the INA 183 (2 x 80 Ω) is to be used with a 1.2/50 µs pulse.

EUT with four lines (two pairs)

The INA 185 (4 x 25 Ω) is to be used with a 10/700 µs pulse. Respectively, the INA 175 (4 x 160 Ω) is to be used with a 1.2/50 µs pulse.

3.3.2 Using CDN 118-T4 with CDN 118-EXT-1 for eight lines coupling

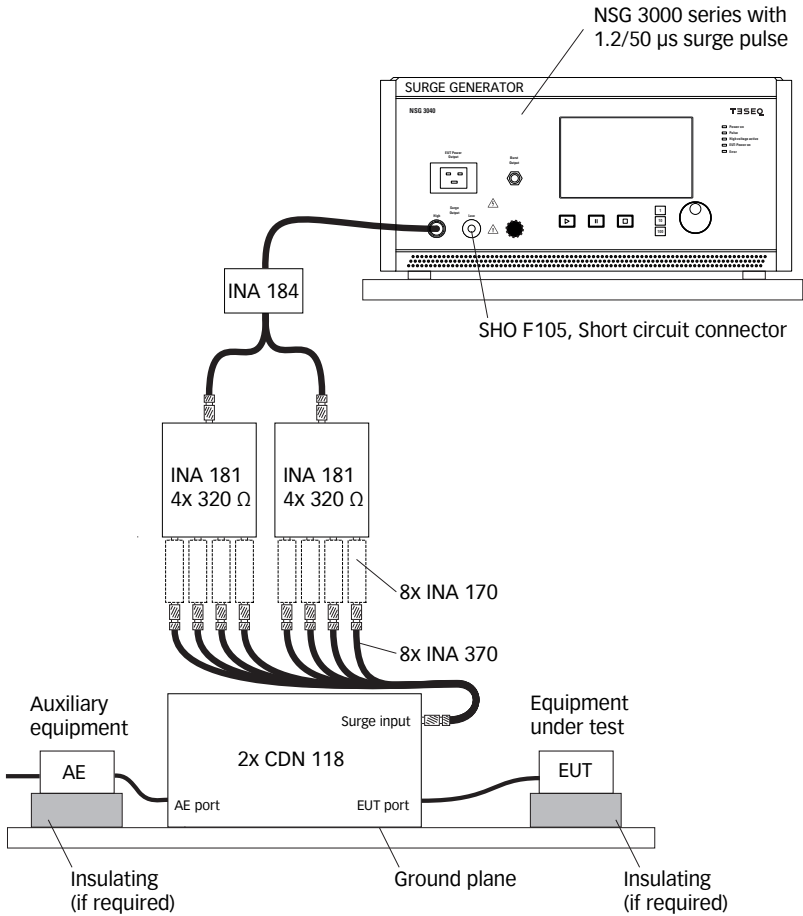

Line to ground coupling with 1.2/50 μ s pulse on telecom lines. CDN 118-T4 extended with option CDN 118-EXT-1 for eight lines coupling

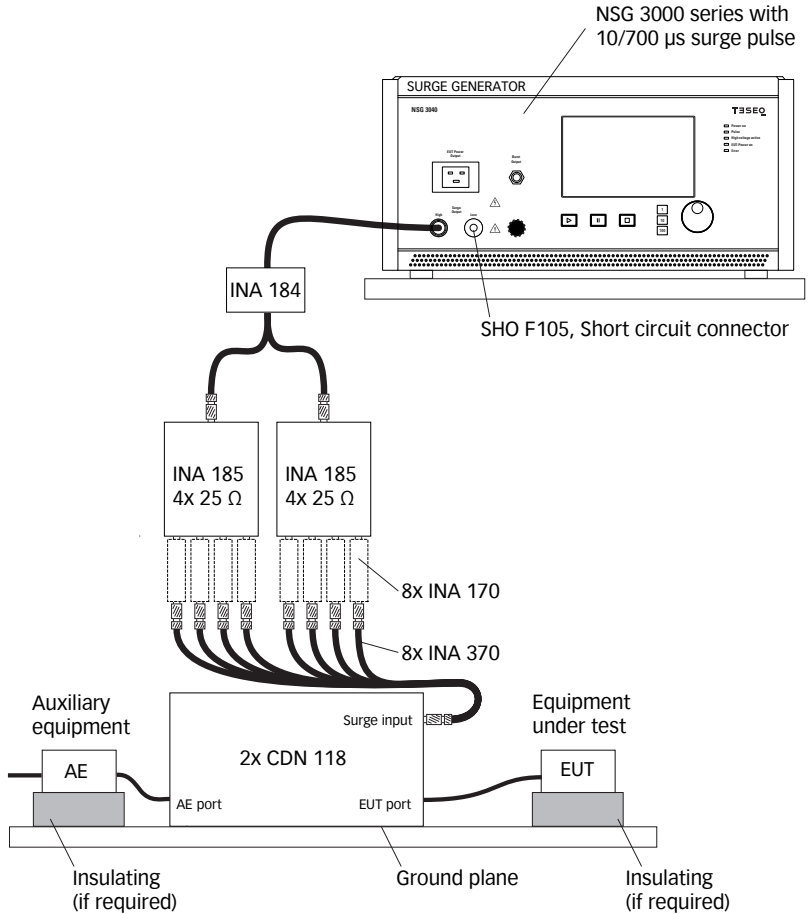

Line to ground coupling with 10/700 μ s pulse on telecom lines. CDN 118-T4 extended with option CDN 118-EXT-1 for eight lines coupling

4 TECHNICAL SPECIFICATIONS



Type	CDN 117	CDN 118
Signal line:		
Maximum operating voltage AC DC	250 V 250 V	250 V 250 V
Maximum operating current	1.5 A	0.5 A
Ohmic resistance per path	< 2.5 Ω	3 Ω
Decoupling chokes 1 kHz	20 mH +/- 20%	20 mH +/- 20%
Symmetrical stray inductance of a pair @1 kHz	Not applicable	50 μ H approx.
Transmission 3 dB BW	800 Hz	250 kHz
Connectors	4 mm safety banana connectors	
Integral resistors	2 x 40 Ω / 6 W	none
Pulse path:		
1.2/50 μ s pulse	6600 V	6600 V line to ground 3000 V line to line
10/700 μ s pulse	not applicable	6600 V line to ground 3000 V line to line
Min. generator impedance 1.2/50 μ s pulse 10/700 μ s pulse	2 Ω Not permitted	2 Ω 15 Ω
Series resistor	2 x 40 Ω , 6 W	none
Maximum pulse frequency	3 per minute	3 per minute
Connectors	5 Fischer type	5 Fischer type

Depending on the impedance setting of the pulse generator, some pulse distortion occurs at the coupler spark gap caused by the inductive loading and the voltage drop.

The 0.5/700 and 100/700 μ s pulses are treated the same as the 10/700 μ s pulses.

INA 170 Spark gap 90 V	Maximum pulse voltage Maximum pulse rate Socket Plug Size (W x H x D) in mm Weight	10/700 μ s pulse 1.2/50 μ s pulse	6600 V 6600 V 3 per minute 1x Fischer type 103 1x Fischer type 103 72 x 25 x 25 0.06 kg
INA 175 Integral resistors 4 x 160 Ω , 6 W	Maximum pulse voltage Minimum series impedance Maximum pulse rate Sockets Size (W x H x D) in mm Weight	1.2/50 μ s pulse 1.2/50 μ s pulse	6600 V 2 Ω 3 per minute 9x Fischer type 103 160 x 160 x 90 2 kg
INA 181 Integral resistors 4 x 320 Ω , 6 W	Maximum pulse voltage Minimum series impedance Maximum pulse rate Sockets Size (W x H x D) in mm Weight	1.2/50 μ s pulse 1.2/50 μ s pulse	6600 V 2 Ω 3 per minute 9x Fischer type 103 160 x 160 x 90 2 kg
INA 183 Integral resistors 2 x 80 Ω , 6 W	Maximum pulse voltage Minimum series impedance Maximum pulse rate Sockets Size (W x H x D) in mm Weight	1.2/50 μ s pulse 1.2/50 μ s pulse	6600 V 2 Ω 3 per minute 5x Fischer type 103 160 x 160 x 90 2 kg
INA 185 Integral resistors 4 x 25 Ω , 10 W	Maximum pulse voltage Minimum series impedance Maximum pulse rate Sockets Size (W x H x D) in mm Weight	10/700 μ s pulse 10/700 μ s pulse	6600 V 15 Ω 3 per minute 9x Fischer type 103 160 x 160 x 90 2 kg

4.1 Environmental conditions

Only intended for indoor applications

Ambient temperature

Normal utilization +5 ... +40°C
Storage and transport -20 ... +70°C

Relative humidity

Nominal working range 20 ... 80%
reducing linearly above 31°C to 50% at 40°C

Condensation

Not permissible under operation

Altitude

Nominal working range < 2200 m
Storage and transport < 12000 m

4.2 Coupling assembly check list

CDN 117 Coupling assembly

Set consisting of:

1 ea.	CDN 117
1 ea.	INA 170 coupler with spark gap only
1 ea.	INA 174A coupler with capacitor
2 ea.	INA 371 coax cable, 0.8 m with connectors (Lemo/Fischer)
4 ea.	Safety laboratory plugs, black
2 ea.	Safety laboratory plugs, yellow/green
1 ea.	Operating manual

CDN 117 – M Coupling assembly

As above but instead of 2 pcs INA 371 supplied with 2 pcs INA 6549 coax cable, with Fischer connectors fitting Modula and NSG 30xx generator family.

CDN 118-T4

Set consisting of:

1 ea.	CDN 118 main unit
4 ea.	INA 170 coupler with spark gap only
1 ea.	INA 173 short-circuit plug (Fischer)
1 ea.	INA 175 matching resistor network, 4 x 160 Ω
1 ea.	INA 183 matching resistor network, 2 x 80 Ω
1 ea.	INA 185 matching resistor network, 4 x 25 Ω
4 ea.	INA 370 coax cable, 0.8 m with connectors (Fischer 103 / Fischer 103)
1 ea.	INA 6549 coax cable, 2 m with connectors (Fischer 105 / Fischer103)
1 ea.	SHO F105 short circuit connector Fischer 105
8 ea.	Safety laboratory plugs, black
2 ea.	Safety laboratory plugs, yellow / green
1 ea.	Operating manual

CDN 118-EXT-1 (option)

Set consisting of:

1 ea.	CDN 118 main unit
4 ea.	INA 170 coupler with spark gap only
2 ea.	INA 181 matching resistor network, 4 x 320 Ω
1 ea.	INA 185 matching resistor network, 4 x 25 Ω
4 ea.	INA 370 coax cable, 0.8 m with connectors (Fischer 103 / Fischer 103)
1 ea.	INA 184 Y cable, 1 m with connectors (1x Fischer 105 / 2x Fischer 103)
8 ea.	Safety laboratory plugs, black
2 ea.	Safety laboratory plugs, yellow / green

5 MAINTENANCE



No maintenance is necessary.

Teseq recommends performing an annual insulation test with a pulse voltage of 6 kV and open EUT outputs. No arcing or internal breakdown should be detectable during the test.

5.1 Warranty

Teseq warrants this instrument to be free of defects in materials and workmanship for a period of two years, effective from the date of purchase.

During this period, any defective component part will be repaired or replaced free of charge or, if necessary, Teseq will replace the instrument with one of equivalent value.

The method of repair / replacement will be at Teseq's sole discretion.

Excluded from warranty are damage or consequential damage caused by negligent operation or use as well as the replacement of parts subject to degradation.

This warranty is rendered invalid by any attempt to modify or repair the instrument on the part of the customer or a third party.

The instrument is to be returned in its original packaging. Teseq can accept no responsibility for damage in transit.

Headquarters

Teseq AG

Sternenhofstrasse 15
4153 Reinach / Switzerland
T +41 32 681 40 40
F +41 32 681 40 48
chsales.teseq@ametek.com

Manufacturer

Teseq GmbH

12623 Berlin, Germany
Landsberger Str. 255
T +49 30 5659 8835
F +49 30 5659 8834
info.rf.cts@ametek.com

China

AMETEK Commercial Enterprise (Shanghai) Co., Ltd. Beijing Branch)

T +86 10 8460 8080
chinasales@teseq.com

Germany

AMETEK CTS Germany GmbH

T +49 2307 26070-0
sales.cts.de@ametek.com

Japan

AMETEK CO., Ltd. Nagoya Office

T +81 52 709 5501
cts-japan.sales@ametek.co.jp

Poland

AMETEK CTS Germany GmbH

T +48 518 643 512
infopolska.cts@ametek.com

Singapore

AMETEK Singapore Pte Ltd. (C/o Teseq Pte Ltd.)

T +65 6484 2388
singaporesales.cts@ametek.com

Switzerland

Teseq AG

T +41 32 681 40 50
chsales.teseq@ametek.com

Taiwan

Teseq Ltd.

T +886 2 2917 8080
taiwansales.cts@ametek.com

UK

Teseq Ltd.

T +44 845 074 0660
uksales@teseq.com

USA

Teseq Inc.

T +1 732 417 0501
Toll free +1 888 417 0501
usasales@teseq.com

© August 2016 Teseq®

Specifications subject to change without notice. Teseq® is an ISO-registered company. Its products are designed and manufactured under the strict quality and environmental requirements of the ISO 9001. This document has been carefully checked. However, Teseq® does not assume any liability for errors or inaccuracies.

To find your local partner within Teseq®'s global network, please go to **www.teseq.com**