

Features

Frequency range of 10 kHz to 400 MHz

Fully compliant with DO-160/ MIL-STD 461

“Air-core” inductors to prevent saturation

Individual Calibration Included



Description

The LI-325 Line Impedance Stabilization Network (LISN) provides the necessary measurement platform for performing power line conducted emissions compliance testing as required by most worldwide standards for commercial products. The LI-325 is compliant with both RTCA DO-160 and MIL-STD 461.

The LISN provides defined stable impedance and isolates the EUT from power source influences, thereby providing accurate and repeatable results.

The LI-325 includes one pair of, separately housed, single-conductor networks, to be installed in series with each current-carrying conductor in a single-phase, dual-phase or DC power system. A second LI-325 pair can be used to accommodate 3-phase power systems (Wye or Delta configurations).

The LI-325 is equipped with Superior Electric SUPERCON® shrouded sockets at the mains (power input) and EUT (power output) ports. The matching color-coded plugs for connection to the mains and EUT wiring are included.

This LISN uses air-core inductors to prevent saturation and permeability variation. The mounting plate of the LI-325 is left unpainted in order to facilitate connection to earth ground in its installation, which is essential due to high leakage current.

All LI-325 LISNs are individually calibrated in compliance with the relevant requirements of RTCA DO-160 and MIL-STD 461. Impedance and Insertion Loss data is supplied with each unit, along with the calibration certificate.

Typical Connection Diagrams

Single Phase connection with one set of LISN

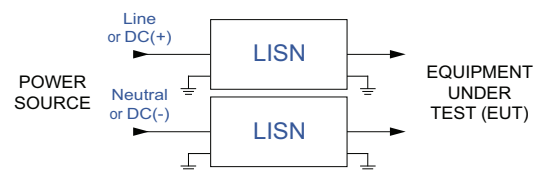

Three Phase connection with two sets of LISNs

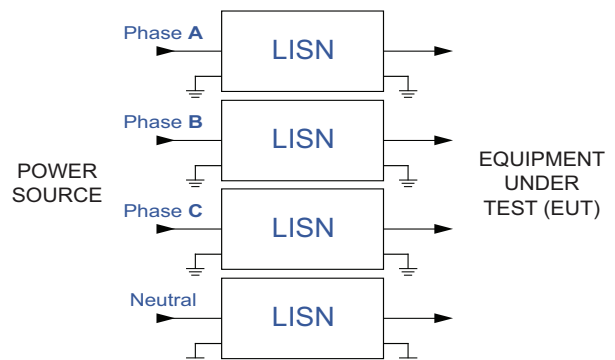

Application

Product Name	Line Impedance Stabilization Network (LISN)
Specification	RTCA DO-160 / MIL-STD 461D
Application	Power line conducted emissions tests
Frequency Range	10 kHz to 400 MHz
RF Connector	50Ω N-type (female)
Current Rating	25 Amperes _(AC) , 17 Amperes _(DC)
Voltage Rating	270 VAC (Line to Ground), 380 VDC
Inductors	5 μH (air-core)
Mains & EUT Connections	Superior Electric SUPERCON ® shrouded sockets
Dimensions (each network)	13 x 7.5 x 8 inches / 33 x 19 x 20 cm
Weight (each network)	5 lbs. / 2.2 kg
Insertion Loss	< 0.3 dB (150 kHz to 30 MHz)

All specifications are subject to change without notice.
All values are typical, unless specified.

